

THE LONG AND SHORT OF SUSPENSION



PART SIX:
UNDERSTANDING
SPRINGS—BOTH COIL
AND AIR—WILL
HELP YOU CHOOSE
THE RIGHT ONES

By Bruce Burness

This chapter deals with the idiosyncrasies of various types of springs. Because motorcycles lean heavily to only two types of springs, coils and air, we will concentrate most of our attention there.

One trait of all springs is that it is impossible to predict their performance without direct field testing or elaborate test equipment. Most of the time it is impossible to make these evaluations until after you have spent your hard-earned money. It is the intention of this article to provide you with enough basic knowledge of springs to insure you purchase what you and your motorcycle need and not just what remains on your dealer's shelf. In the first article of this series (Suspension Part I, *Motorcyclist* September, 1977), we covered the basics of springs in detail. Here I will quickly review the essential concepts and relevant terminology.

The term we will refer to most often is *spring-rate* or *rate*. Spring-rate is a measure of a spring's stiffness or ability to withstand various loads. Specifically spring-rate is the amount of load or force required to collapse or compress a spring one inch. In this country it is expressed as pounds per inch (lbs./in.); in the metric system it is kilograms per centimeter—KG/CM. If you apply a force of 300 pounds to a spring and it compresses 3 inches, it is said to have a 100-lb./in. rate:
 $300\text{-pound load} = 100\text{ lbs./in. rate}$
3-pound deflection

It is very important not to confuse spring-rate with spring load. Load is the amount of force or pounds applied to the spring—for a motorcycle this is the weight of the chassis and rider multiplied by the leverage of the spring-shock mountings.

If you know the load and you know the spring-rate you can predict the amount of *spring deflection*. For example if you have a 300-pound load and you apply it to a 100-lb./in. spring you will get 3 inches of spring deflection:

$300\text{-pound load} = 3\text{-inch deflection}$
100 lbs./in. rate

The spring rate determines how a spring reacts or deflects to changes in load.

Free length is the length of a spring before any load is applied or when it is standing free of its intended installation. If you know the amount of spring deflection due to the combination of load and rate, you can determine the *loaded length* by subtracting the deflection from the free length:

10-inch free length

-3-inch deflection

7-inch loaded length

Many times the deflection caused by the static load is referred to as *preload*. *Mechanical preload* is the amount the spring is compressed when it is installed in the suspension. *Static preload* is the mechanical preload plus the additional amount the spring compresses when it is supporting the chassis while at rest. Sometimes the mechanical preload is greater than the static preload. When this condition exists the suspension does not move until a bump large enough to overcome the mechanical preload is encountered. This is a condition to be avoided at all costs.

Now let's look into why one spring is stiffer than another. When a spring engineer is asked to design a spring with a particular spring-rate, he has three variables at his disposal. The first is the number of *active coils* he can fit into the requirements. Active coils are the coils that do not touch each other and generally there are two less active coils than total coils—one dead coil being provided at each end to square the ends. Secondly he can select various thicknesses of *spring wire* to cause the rate to go up or down—the thicker the wire, the higher the rate. The last variable is the *mean diameter* of the spring. The mean diameter is measured from the center of the spring wire on one side of the spring to the center of the wire on the other side. The selected combination of these three elements determines the spring-rate of each spring. The difficult part for you and the cause of such confusion about

spring stiffness is that two of the elements work inversely in relation to spring-rate. By that I mean that if you use more of one of those elements you get less spring-rate. Conversely if you use less you get more spring-rate. Understanding this concept is vital for full comprehension.

The two elements that are inversely proportional are the number of coils and the mean diameter. The size of the spring wire is directly proportional to spring-rate—the bigger the wire, the stiffer the spring. For illustration purposes, imagine a coil spring unwrapped and straightened into a rod or bar. Now clamp one end solidly and support the other end in a bearing. Add a lever arm to the end of the bearing and we have a torsion bar (**figure 1**). If you pull on the end of the lever arm with a load the bar will twist in torsion at a specific spring-rate. The bar's resistance to twisting is generated by the interaction of the molecules working in shear against each other.

Glance at **figure 1** again and notice the cross section of the bar projected off the end. The pie-shaped piece represents the amount of twist (or relative motion between molecules) from the clamped end to the free end due to the load. Notice the pie section is much wider at the surface than near the center. This indicates the molecules at the surface must resist movement much more than those at the center. This is the reason spring-rate will increase if you increase the bar or wire size. Incidentally the stiffness increases to the fourth power of diameter. Also notice the center of the bar contributes very little to the stiffness which accounts for tubular bars being nearly as stiff as solid bars. I throw this in as an idea for saving weight.

Just like our original coil spring, bar size is not the only factor in determining the stiffness. The length of the bar is the other variable. Although it may be easy to comprehend that a larger diameter bar will be stiffer, it may not be so easy to accept that shortening the bar will

also increase the stiffness. Think again of the molecules tugging on each other creating a resistance to twist. A longer bar will have more molecules in it than a shorter bar. Each of those individual molecules is going to equally feel the total or all of the load or stress being fed into the bar. Each molecule will deform a specific amount when stress is applied. The amount of twist is the sum of the deformation of all molecules. The bar with more molecules, or longer bar, will twist more. Conversely, a bar with less molecules, or shorter bar, will twist less.

Why are we so preoccupied with torsion bars when our motorcycles come equipped with coil-springs? Keep in mind that a torsion bar is simply a straightened coil spring. A coil spring exerts exactly the same twisting action in its wire and all the same principles apply. A further direct relationship is that the length of a torsion bar has an effect on two of the spring-rate variables found in coil springs.

If you take that bar and coil it up, it will make just so many coils of a certain mean diameter before you run out of bar. If you want more coils or larger diameter coils you must start with a longer bar. That will make the coil spring softer. If you add coils or make larger coils, the spring-rate will be lower. If you remove coils or shrink the diameter, the spring-rate will be higher.

Unfortunately the engineer's prob-

FIGURE ONE
UNWRAPPED COIL SPRING (TORSION BAR)

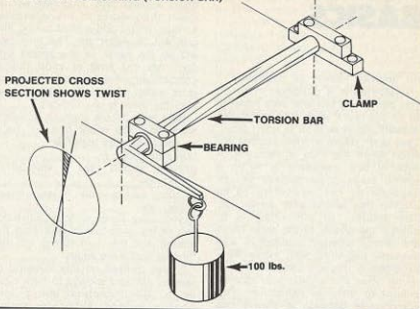

lems are not over once he has arrived at a combination that will produce the desired spring-rate. Generally the diameter of the spring is governed by whatever the spring goes over or into and cannot be varied much. One of his options is gone before he starts. The free length and travel are also likely to be predetermined. That means his combination of wire size and number of coils must not take up too much length when the spring is fully compressed,

or coil-bound. *Coil-bind* is when full compression causes the coils to touch and become *shorted out* and/or *dead coils*. If they all touch the spring becomes solid.

If an engineer discovers his combination has too many coils to yield the required amount of travel before coil-bind, he can remove some coils, which will raise the rate. Then he must reduce the wire size to bring the rate back down again. This may solve the travel problem, but brings

FIGURE TWO
HOW VARIOUS TYPES OF COIL SPACING RESULTS IN DIFFERENT RATE CURVES

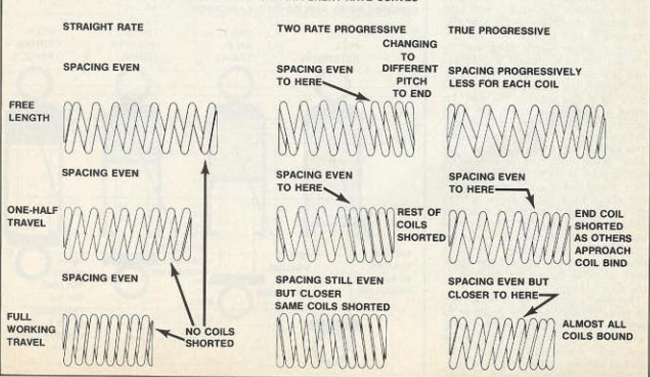

SUSPENSION BASICS

on another known as *overstress*.

Overstress is a condition in which you are asking too little wire material to do too much work. The molecules actually slip in relation to each other. They don't return to their original position when the load is removed. A sign of this condition is when a spring takes a permanent set or sags-out by not recovering to its original free length after some use. The solution to this crisis is to change the quality of the wire. There are several different qualities of wire available beginning with *music wire*, progressing through various oil tempered types and ending with *chrome silicon* or *chrome vanadium*. The compromise decision is always one of cost. If a spring doesn't require a wire with a high stress capability, it is purely academic to use expensive wire. Most motorcycle springs are made from oil tempered wire, but chrome silicon is being used occasionally for long travel suspensions.

The message of all this dialogue is that it is possible for a spring with few coils and tiny, quality wire to be every bit as stiff as a spring that is more massive. Don't assume because a spring looks light that it is not stiff.

So far we've been talking about springs that have just one rate. Today's motorcycles seem to respond to suspensions that have a soft rate for general conditions and a dramatic increase in rate to deal with the occasional larger bump. One way to achieve this is to design a *progressive rate spring*. If you think back to our torsion bar, recall that the rate goes up if you shorten the bar. To make a progressive spring we must accomplish this shortening in stages as the spring is being compressed. The easiest way to do that is to take away active coils one at a time by having them short out on each other. This leaves fewer and fewer remaining active coils causing the rate to go up. **Figure 2** illustrates how the coils can be spaced in order to give various kinds of rate curves. The drawback to progressive springs is that it is difficult to get enough travel with all those dead coils stacked in the spring length.

Another approach is to stack two or three different springs together to get maximum utilization of the spring wire. This system provides more travel and, even more significant, a wider spread between initial and final rate. Remember when you stack springs

together the effect is that of one spring with more coils. More coils mean a lower rate. That rate will be lower than either of the individual springs. If you add a third spring, the rate will be softer yet. The final rate will be the same as the spring that does not coil bind or short out. A combination of travel and rate determine which spring will still be active after the other is shorted out.

Here is a simple formula to determine what the initial rate will be if you stack springs together:

$$\text{Low spring-rate} = \frac{\text{primary spring rate} \times \text{secondary spring rate}}{\text{spring rate}}$$

$$\text{primary spring rate} + \text{secondary spring rate}$$

If you have three springs, solve for two of the springs first and plug the answer and the third spring into the formula and solve again.

I have dwelled on this lowering of rate for stacked springs to help clear up a misconception about fork booster springs. A booster spring does not make a spring stiffer, only longer, in fact it makes the spring softer. However if a booster spring is installed inside or outside another spring (in parallel instead of in series) the rate does go up and is the sum of the two rates.

The amount of desirable progression has a lot to do with the type of shock mounting geometry incorporated. If your motorcycle has geometry that causes a diminishing rate you will need more progression than if you have a rising rate geometry.

(Suspension Part 3, *Motorcyclist* November, 1977).

Here are some general guidelines to help you select spring progression. Suppose the optimum straight rate spring for your motorcycle is 100 lbs./in. For a progressive spring I would start with about an 80-lb./in. initial rate and end up with about a 160-lb./in. rate after about 3/4 of the travel. That is a rate spread of 100 percent which is about right for most shock geometries. Laydown or diminishing mountings will need a greater spread than 100 percent and more upright or maximum rise geometries will need a lesser rate spread.

The damping characteristics also influence the amount of rate spread. A lot of compression damping will minimize the need for rate spread and also allow you to start with lower initial rates. Remember to always use an initial rate lower than the optimum straight rate.

It is possible to measure spring-rates yourself. If you want to know if a spring is just harder or softer than your existing spring you can count the coils and measure the spring wire to make a quick estimate. If you want to know the actual rate this can be done with a bathroom scale and a drill press. This operation can be dangerous so I suggest extreme care. Place the bathroom scale on the drill press table and brace the top of the scale so the load from the spring will be evenly distributed. Now make some kind of pushing device to fit in or over the drill press chuck.

FIGURE THREE
BOYLE'S LAW AS APPLIED TO AN AIRSHOCK

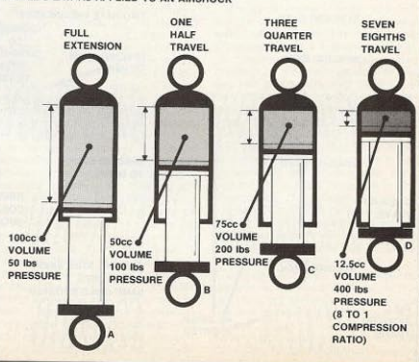

Try to make the pushing device act as a guide to keep the spring from flying out. Compress the spring a little to make sure the end coils are truly shorted out. Take a reading from the scale now. Compress the spring exactly one inch and take another scale reading. If your scale will handle it compress the spring another inch to get an average or an indication of progression. If you subtract the initial reading from the second and the second from the third, you will have two spring-rates. Average the two for the actual rate. Be very careful to keep everything in line when performing this operation, otherwise the spring will be likely to fly out of the drill press.

That's enough about coil spring. Let's get on to air-spring. Air springs, used commonly today in both forks and shocks, have the unique quality of being naturally progressive. In practice, the initial rate can start lower and the final rate can end up con-

siderably higher than is possible with conventional springs. Additionally the individual owner can perform easy adjustments to create an infinite number of spring-rate curves. It sounds as if air springs are the complete answer. But just like everything else in this world, you can't get something for nothing. The problems of air springs are many and only the individual who is willing to tolerate the annoyances will be able to enjoy the advantages.

First we have the problem of making sure this air-spring device doesn't spring any leaks. This requires that all the parts involved are kept in perfect condition. This also requires an investment in tanks, regulators and gauges in order to monitor the pressure all the time. Air-springs generate a lot of heat when the air is compressed. This heat causes the air to expand, which causes more pressure which causes the spring-rate to change. Change in spring-rate due to

temperature change is the Achilles' heel of most air-spring designs. Another problem is the increase in seal friction caused by internal air pressure forcing the seal outward against its sliding surface. This extra seal friction acts as excess damping and many times completely negates the benefits of the low initial spring-rate by causing "stiction." In spite of all these and many more problems, air-springs still offer possibilities not available by any other method.

First let's see why air-springs are naturally progressive. The answer lies in one of the laws of physics. "Boyles Law" states that if you compress a gas by reducing its volume, the pressure will rise inversely proportional to the change in volume. Simply stated, if you cut the volume in half, the pressure will double.

In figure 3 we have applied Boyles Law to a typical air shock configuration. The illustration shows an air chamber whose volume can be reduced by a piston moving up from the bottom. Position A shows the device fully extended. Position B shows the volume cut in half and the pressure doubled. In Position C the volume is halved and the pressure is doubled again. Notice we had to move the piston only half as far this time to double the pressure. In Position D the volume is reduced by half once again, and this time it was only necessary to move the piston one-quarter of the original change in distance. As you can see, the pressure quickly escalates near the end of travel. This pressure exerts a force on the piston to drive it back out of the cylinder and that is the spring resistance you feel. The amount of force you feel is the product of the pressure times the area of the piston.

Our illustration shows a cylinder with a very high compression ratio. (Compression ratio is the original or starting volume divided by the remaining volume at the end of travel). Figure 4 charts the spring rate curves of several different compression ratios. In all cases, the amount of stroke or change to the volume is the same (80cc). The starting volumes do vary and of course the final volumes change accordingly. This kind of volume change can be accomplished with an air-fork or air shock by the simple addition or subtraction of oil fill. Notice it is the final spring-rates that are affected the most by compression ratio changes. Study the chart carefully to appreciate how sensitive air-springs are to volume changes. Especially notice the dramatic final rate increases associated with the higher ratios.

The extreme rise in pressure can
continued on page 88

FIGURE FOUR
PRESSURE CHANGES RESULTING FROM VARIOUS COMPRESSION RATIOS.

STARTING VOLUME	TRAVEL	VOLUME	PRESSURE	PRESSURE CHANGE
150cc	EXTENDED	150cc	10 LBS.	—
	1/4	130cc	11.54	1.54 LBS.
	1/2	110cc	13.64	2.10
	3/4	90cc	16.67	3.03
	FULL BUMP	70cc	21.43	4.76
100cc	EXTENDED	100cc	10 LBS.	—
	1/4	80cc	12.50	2.50 LBS.
	1/2	60cc	16.67	4.17
	3/4	40cc	25.00	8.33
	FULL BUMP	20cc	50.00	25.00
90cc	EXTENDED	90cc	10 LBS.	—
	1/4	70cc	12.86	2.86 LBS.
	1/2	50cc	18.00	5.14
	3/4	30cc	30.00	12.00
	FULL BUMP	10cc	90.00	60.00
85cc	EXTENDED	85cc	10 LBS.	—
	1/4	65cc	13.08	3.08 LBS.
	1/2	45cc	18.89	5.81
	3/4	25cc	34.00	15.11
	FULL BUMP	5cc	170.00	136.00

FIGURE FIVE
PRESSURE CHANGES RESULTING FROM VARIOUS STARTING PRESSURES

STARTING VOLUME	TRAVEL	VOLUME	PRESSURE	PRESSURE CHANGE
5 LBS.	EXTENDED	100cc	5 LBS.	—
	1/4	80cc	6.25	1.25 LBS.
	1/2	60cc	8.33	2.08
	3/4	40cc	12.50	4.17
	FULL BUMP	20cc	25.00	12.50
10 LBS.	EXTENDED	100cc	10 LBS.	—
	1/4	80cc	12.50	2.50 LBS.
	1/2	60cc	16.67	4.17
	3/4	40cc	25.00	8.33
	FULL BUMP	20cc	50.00	25.00
15 LBS.	EXTENDED	100cc	15 LBS.	—
	1/4	80cc	18.75	3.75 LBS.
	1/2	60cc	25.00	6.25
	3/4	40cc	37.50	12.50
	FULL BUMP	20cc	75.00	37.50
20 LBS.	EXTENDED	100cc	20 LBS.	—
	1/4	80cc	25.00	5.00 LBS.
	1/2	60cc	33.33	8.33
	3/4	40cc	50.00	16.67
	FULL BUMP	20cc	100.00	50.00

MOVING?

DON'T MISS A SINGLE ISSUE OF MOTORCYCLIST!

Let us know your new address right away. Attach an old mailing label in the space provided and print your new address where indicated.

TO SUBSCRIBE OR EXTEND YOUR SUBSCRIPTION—

Check the appropriate boxes below:

New subscription. Please allow us up to 60 days to get the first copy into the mail.

Renewal subscription. Please include a current address label to insure prompt and proper extension.

1 year \$9 2 years \$16 (U.S. Territories & Military only. Other countries add \$3 per year.)

Payment enclosed or Bill me (U.S. only)

Name _____

Address _____

City _____ State _____ Zip _____

MAIL TO:
MOTORCYCLIST
675 Sunset Blvd.
P.O. Box 3289
Los Angeles, CA 90028

ATTACH
LABEL
HERE

(If label is not handy, print OLD address in this space.)

SUSPENSION

continued from page 26

sometimes be more than is desirable. Some of the current air-spring designs now incorporate some method to allow the volume in the cylinder to stretch or increase after a certain pressure is reached. This is accomplished by a secondary floating piston or a diaphragm with adjustable pressure behind it. The theory is to create a gentler increase in spring-rate near the end of travel when higher starting pressures are used and in fact this second adjustment gives an almost infinite number of combinations.

Another approach common today is to augment air-springs with a soft straight-rate coil spring. This is done for two reasons. First, less pressure is required to keep the motorcycle at an acceptable ride level. (If you start with less pressure the final rates will not be so severe.) Secondly, the problem of seal friction is reduced and the forks regain sensitivity over small bumps.

The starting pressure is another tunable adjustment, but it affects the spring-rate in quite a different manner than the compression ratio. Figure 5 charts the effect of several starting pressures. The change in volume is again 80cc and the starting volumes remain constant.

Notice that changes to starting pressure affect the initial rates more than was the case with changes to the compression ratio. Notice also that they affect the final rates much less than compression ratio changes. By juggling starting pressure and starting volume you can tailor a spring-rate curve that exactly matches the demands of your bike.

Let's see how we might apply all this theory directly to your motorcycle, and particularly to your front forks. Suppose while test-riding you conclude the forks are too stiff and don't travel the full amount, so you lower the starting pressure. Suppose this change doesn't help the feel very much and the fork travel is still incomplete. This is a good indication the problem is actually too much oil fill. Drain out a little oil and make another pass over your favorite motocross course. A possible result could now be a general improvement and complete travel but also a loss of damping control over small bumps (chatter). This indicates the forks need the extra oil to keep the damping parts submerged at all positions of travel. The solution now is to add oil to restore the oil level to its original height. Then provide more air space above the oil by adding a res-

continued on page 93

J&R PERFORMANCE FITS YOU

YOUR MOOD • YOUR STYLE • YOUR BIKE



COMPETITION



STREET LEGAL

- YOUR CHOICE**
- STREET LEGAL with EXCLUSIVE J&R RETRO-FLOW BAFFLE, or
 - COMPETITION RIDING with HIGH PERFORMANCE GLASS/PAK SILENCER

WITH • EVERY J&R 4-STROKE SYSTEM AT NO ADDITIONAL COST

EASE • JUST 5 MINUTES + 1 BOLT

J&R has two-stroke and four-stroke exhaust systems and replacement mufflers available for most Honda, Kawasaki, Suzuki and Yamaha motorcycles.

100% warranty against defects in material or workmanship.



See your local dealer today, or send \$1.00 for a catalog and decal.

550-B West Mercury Lane
Brea, CA 92621 (714) 990-5500

Member



Your bike should have come with them.

Since it didn't we think you're missing something. In fact, several somethings. Like uniform control, riding comfort, total suspension adjustability and simple convenience.

The new Mark II Air Adjustable System is totally and infinitely adjustable so that you can fine-tune your rear suspension to keep your bike's handling constant under all load conditions.

You add and release air in the "System" through a convenient handlebar mounted air valve/gauge unit. The gauge helps you make fine adjustments.



to pressure in the "System" and also gives exact readings so you easily pressurize the "System" for familiar loads. The optional pocket-size hand pump makes on-the-road pressure changes easy.

No conventional coil spring damper unit can compare to the S & W Mark II Air Adjustable System for safety, comfort and convenience.

We have a "System" to fit all major brand large displacement street/touring bikes including Harley-Davidsons and Hondas requiring clevis joint mounting. Shock units available in solid black or bright chrome plated.

A 1-valve kit is supplied as standard equipment. The gauge and pump as illustrated, are optional.

S&W Engineered Products

Send \$3.50 (Canadian \$4.00) for 1978 Catalog/Engineering Handbook. This includes handling and mailing. California residents add 6% for sales tax.

P. O. Box 2007 Anaheim, CA 92804

SUSPENSION

continued from page 88

ervoir or extending the fork caps. With the oil level optimized you can once again survey various starting pressures. You may also have to play with the volume of the new reservoir in order to get the ratio just right.

A side effect to these new spring-rate curves may be that the hydraulic damping will have to be adjusted to match. Many times a new spring-rate curve will be sabotaged by incorrect damping. Don't disregard any "pressure/fill" combination until you are confident the damping has first been optimized. This can normally be accomplished by changing the viscosity of the fork oil.

Another possible condition is that no matter how high you make the starting pressure the motorcycle forks still bottom-out. This indicates too low a compression ratio. Add some extra oil to correct this condition. If you find that you can't get a combination that works freely over little bumps without bottoming you might consider a light helper spring to augment the air-spring. Be sure to use slightly lower starting pressures in conjunction with a helper spring.

When performing these tests, keep in mind that the various combinations of spring-rate curves overlap and interact in an intricate manner. Any single adjustment may require one or two adjustments of other elements in order to completely evaluate your results. The perfect combination may be elusive but very satisfying once it is achieved. *M*

Next Month! Laverda's 1200cc Lion

10-Page Accessory Guide In Color

SWM Dirt Test

Learn Motorcycle Repair

★ TRAIN AT HOME TO BE A

Motorcycle Mechanic



If you like to ride a cycle for fun... learn how to fix it for profit! Can you imagine a better way to earn your living, whether you choose to work in a cycle shop for someone else or decide to start your own cycle repair business? Now, thanks to North American, there's a fast, easy way to get training at home in your spare time.

No need to quit school or your job. Experts show you step-by-step everything from minor tune-ups to major overhauls.

CYCLES ARE BIG BUSINESS... AND SO IS FIXING THEM!

There are more than 5 million cycles registered in the U.S. today. Plus an estimated million more dirt bikes. And they all need maintenance. Customers in every climate area, and we cannot promise you a job. But if you're serious, we'll send you one of our graduates seeking work found jobs.

INCLUDED TO START YOU FAST! SPECIAL CYCLE TOOLS & TEST INSTRUMENTS



NORTH AMERICAN SCHOOL OF MOTORCYCLE REPAIR
4300 Campus Drive, Dept. ECO 58 Newport Beach, CA 92663

Rush free color brochure and full information on how I can learn motorcycle repair for only a few dollars a month.

NAME _____ SEX _____

ADDRESS _____

CITY _____ STATE _____ ZIP _____



SUPER BIKE WRENCH Remarkable New Universal Wrench Handles Both Standard & Metric

The perfect compact tool for any bike, this universal wrench adjusts to up to 40 different sizes, instantly. It can handle standard nuts from 3/8-inch to 13/16-inch, and all metric sizes from 9mm thru 22mm. Its unique design, which grips nuts and bolts on three sides, enables tightening for loosening of even severely deformed nuts, prevents damage to good nuts. Ratcheting, box-end and crescent features are combined in one unit. The 37-teeth wrench is made of chrome vanadium steel and can handle any kind of nut: square, hex, etc. \$6.95 post-paid and fully guaranteed. Howard Products Co., Dept. CY, P. O. Box 57246, Dallas, Texas 75207.

GENUINE BMW PARTS

20% OFF CURRENT
DEALER LIST
Price List upon request.
Parts shipped anywhere.

**CAPITAL
CYCLE
CORPORATION**

**CAPITAL CYCLE
CORPORATION**

2328 Champlain St., N.W.
Washington, DC 20009
phone (202) 387-7360